



WINDOW NATION

WINDOWS • SIDING • DOORS

ULTRAVISION

ULTRAVISION



Vinyl Colors

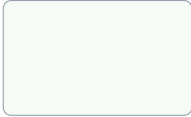

White



Almond

Grid Styles

Colonial

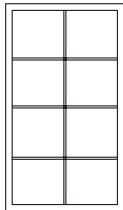
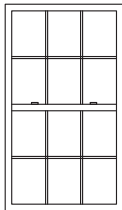

Prairie

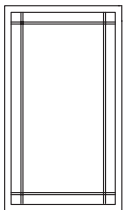
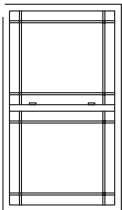

Craftsman

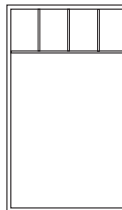
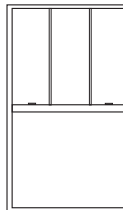

Flat or contoured grids available. This is just a sampling, several grid patterns are available. Grid pattern availability and appearance is based on window size and shape.

ULTRAVISION is also available in sliding windows, casement and awning windows, picture windows, and sliding doors.



Sliders come in 2- and 3-lite models. 3-lite sliders have a center fixed panel and are available in configurations of 1/3-1/3-1/3 and 1/4-1/2-1/4 .



Casements have a unique hinged design that allows for easy cleaning from the inside of your home.



Patio doors are built strong, including a heavy-duty metal reinforcement and an extruded aluminum screen door frame, while still remaining aesthetically appealing.

Providing Structural Integrity and More Affordable and Pleasing Aesthetics

1. World-Class Assembly

Consistent fabrication quality from window to window. Fusion-welded sashes and frame are built squarely. Narrow manufacturing tolerances produce a tight window that prevents air infiltration.

2. Wet-Glazed Process

Secures glass in sash for a tight seal and delivers industry-leading air infiltration rates.

3. H-LC40 Performance

High structural rated performance is achieved without the need for a sill rise extender, improving clear opening.

4. Wool-Pile Weatherstripping

Protects around the perimeter of all sashes to fight air infiltration.

5. Integral Ergonomic Lift Rails

Features durable, comfortable ergonomic design.

6. Interlock System

Interlock at sash meeting rails creates a super-tight seal against air infiltration, providing security, comfort and well being.

7. Tilt-in Sash System

Dual operating tilt-in sashes make cleaning safe and easy from inside the home.

8. Dual Vent Latches

When deployed, limit sash travel, allowing for a secure way to keep windows open for ventilation.

9. Block and Tackle Balance System

The premier Block and Tackle Balance system ensures that lifting and closing will be smooth, reliable and quiet for years.

10. Balance Covers

Give the window a more attractive and finished appearance.



Stainless Steel Intercept Spacer System

- Corrosion-Resistant - Will not rust
- Temperature Resistant - Maintains a strong, secure seal through temperature changes
- Strength and Durability - Stronger than tin and aluminum spacers
- Warm-Edge Technology - Less conductive than typical aluminum and tin spacers for better energy efficiency
- Grid Alignment - Perfect, machine-generated alignment
- Aesthetic Appeal - Beautiful shine, the best-looking spacer in the industry

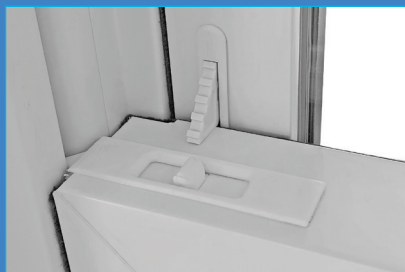

Vent Latch when deployed, will limit sash travel to allow for ventilation.



Fusion-welded corners prevent air from passing through and boost structural support.



Cam-action lock features durable zinc-cast design that pulls sashes and mechanical interlock tightly together to prevent air infiltration.

Air Infiltration

Poorly designed windows don't have built-in airlocks, weather-stripping, and barriers necessary to keep air from forcing its way in, and leaky windows cause drafty homes. ULTRAVISION windows greatly minimize air leaks with numerous air barriers designed into our advanced sill design.

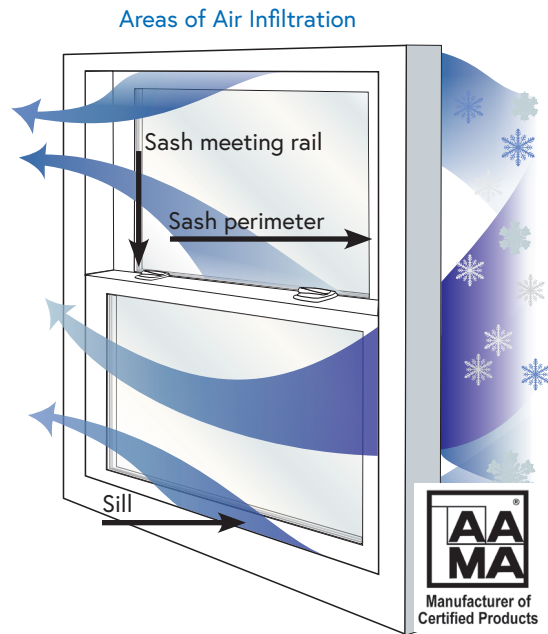

Structural Data	
Air:	0.07 cfm at 25 mph*
Structural:	DP 40

Glass

The ULTRAVISION window comes standard with one of our double-pane, high-performance Low-E glass systems with the stainless steel spacer system, which helps to dramatically improve the efficiency of your new windows.

Low-E

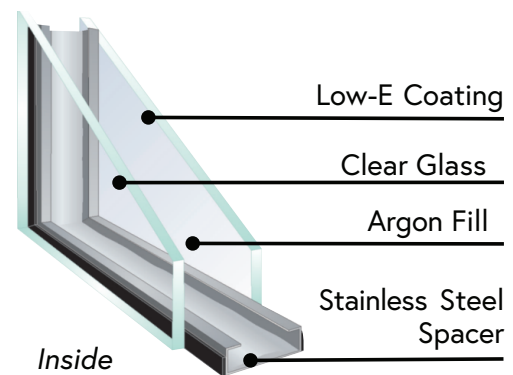

* Up to 77% better than industry minimum .30cfm

** psf Pressure measurement = Pounds per square foot (Lbs./ft²)

Test results vary by style and size of window. Size tested is 48x84

Windows Assembled in the USA

ULTRAVISION windows are manufactured in the USA and are designed and engineered specifically for our challenging Midwest and east coast climates. This weather is unlike any other in the country due to its hot, humid summers and brutally cold and snowy winters. Why purchase a window made for the entire country's average weather when you can invest in one designed for your unique climate? Other benefits of products include:

- No shipping costs
- Quicker turnaround
- Supports economy
- Windows specifically designed for our challenging climate
- Quicker service for parts

A Lifetime of Protection

All Window Nation Products are manufactured by the recognized leader in product innovation with uncompromising quality control. From the day your windows are installed to the day you sell your home, our comprehensive non-prorated lifetime warranty is your assurance that your investment is protected. Additionally, your warranty is completely transferable to the next homeowner. Contact a Window Nation consultant for more information and a copy of the warranty.

Reputation Built on Decades of Experience

Window Nation, Inc. was started by the Magden brothers with the mission of offering an unsurpassed selection of premium name-brand products installed by highly skilled licensed professionals and guaranteed by the most comprehensive warranty in the industry. Window Nation is consistently listed nationally as a top 20 window retailer, offers an award-winning customer service experience, maintains the grades via 3rd party review sites, and continues to deliver a 96 percent customer satisfaction.

Unmatched Installation Experience



Great windows are only great if they're installed properly. It's critical that all components that go into your new windows work together – insulation, caulking, sealants, and the window itself.

It Starts with Quality Materials

① OSI QUAD Low-Expansion Foam

- Single-component, minimal expansion and low-pressure polyurethane foam specifically designed for replacement window applications
- Ideal foam for sealing gaps, cracks, holes, or voids around windows
- Closed-cell structure of this material provides an R-factor of 5 per inch of cured foam, making it an efficient method for reducing air and moisture infiltration

② OSI® QUAD MAX® Window, Door, and Siding Sealant

- Unique multi-polymer formula specially engineered for premium replacement window installations
- Permanently flexible — will not crack or split even in extreme temperatures
- Water-resistant, all-weather applications, sticks to wet surfaces with no water washout
- Excellent UV resistance — will not crack or yellow

③ High-Performance Trim Coil

- Outperforms PVC and Poly Coil finishes in the ASTM physical tests performance
- Features a finish with 8 mils of paint; that's twice the amount of paint used by most trim coil manufacturers
- Scratch-resistant, stain inhibitors, better UV protection, and harsh-climate coating

④ Concrobium Mold Control Spray

- Innovative, market-leading product that effectively eliminates existing mold, prevents mold re-growth, and eliminates musty odors with no harmful chemicals
- Effectively eliminates and prevents mold with no bleach, ammonia, or VOCs
- Works as it dries by crushing the mold spores at the roots, leaving behind an invisible antimicrobial barrier to prevent future mold growth

Window Nation currently serves the following areas:

Colorado • Connecticut • Delaware • Georgia • Illinois
• Indiana • Kansas • Kentucky • Maryland
Massachusetts • Minnesota • Missouri • New Jersey
North Carolina • Ohio • Pennsylvania • Tennessee
Texas • Virginia

WINDOW NATION
WINDOWS • SIDING • DOORS

866.446.2846
www.WindowNation.com

WHY WINDOW NATION?

OVER 2,000,000 WINDOWS INSTALLED IN MORE THAN 150,000 HOMES

ATTENTION TO DETAIL



- 50 Point Factory Inspection
- 20 Point Installation Review
- 96% Customer Satisfaction On Clean Up And Safety
- Custom Windows Measured 3 Times To Ensure Precision, Accuracy And A Tight Seal
- Installed more than 1.5 million windows, 96% requiring no follow up service

QUALITY



Window Nation Uses America's Only Integrated System Of Window Installation Materials, Insulation, Sealant, And Caulking

- OSI Quad Foam
- OSI Quad Max Exterior Sealant
- Ultra-Premium High Performance Exterior Trim Coil
- Concrobium Mold Spray Treatment

EXPERIENCE



- Installation Crew Leaders Average More Than 20,000 Windows & 15 Years Experience
- Service Technicians With An Average Of 15 Years' Experience
- 1,500,000 Windows Installed In Over 150,000 Homes
- 3rd Largest Window Retailer In The Country, Ranked By Door And Window Market

PRODUCT SELECTION



- Over 1,500 Custom Window & Door Style Combinations
- Name Brand Windows Available
- Energy Star Rated Products
- Windows Engineered For The Specific Climate We Live In

TRUST



- Angie's List Super Service Award Winner
- Limited Lifetime Warranty
- Exclusive 30-Day Price Protection Guarantee
- Licensed, Bonded, And Insured

WN
WINDOW NATION
WINDOWS • SIDING • DOORS

866-446-2846
WindowNation.com

